

SERIES 35-62 - 60730-2-5 Compliant



24 VAC Microprocessor Based Direct Spark Ignition Control - Dual Point

F-35-62H
February 2024

FEATURES

- Dual Direct Spark Ignitors (DSI)
- Single or Multiple tries for ignition (TFI)
- Multiple options for ignition period, pre-purge, and inter-purge timings
- Diagnostic Red LED
- Flame Sense Yellow LED
- Dual Local or Remote flame sensing
- Quick connect terminals or Multi-pin header
- Integral Brass Standoffs or Enclosure available
- Available one-hour automatic reset
- Communications and Alarm Out available
- Fan Control Board available
- Meets 60730-2-5 Harmonized Standard

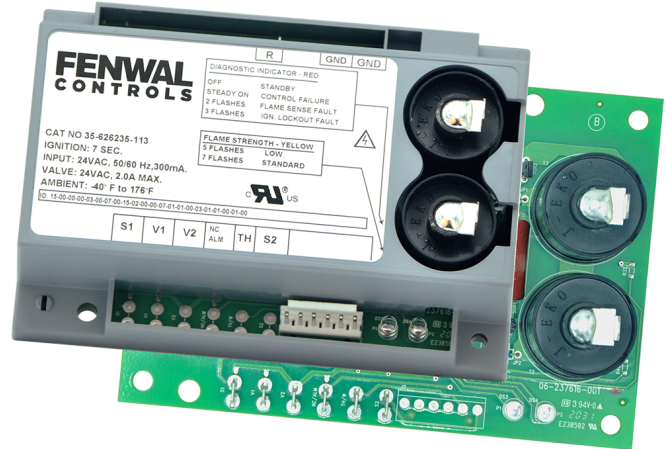

APPLICATIONS

- Commercial Cooking
- Radiant Heaters
- Gas Furnaces
- Boilers

DESCRIPTION

The Model 35-62 is a 24 VAC Microprocessor Based Dual Direct Spark Ignition Control designed for use in all types of heating and Commercial Cooking applications where the appliance has two burners. The control uses a microprocessor to continually and safely monitor, analyze and control the proper operation of the gas burner. A Fan Control Accessory Board is available and can be added if an inducer fan control is required.

UART COMMUNICATIONS

Series 35-62 has an optional UART communications port, that when paired with the Fenwal Series 05-50 Communication control provides remote monitoring. Contact Fenwal Controls for additional details.

Agency Certifications

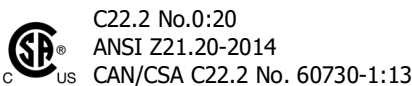

RoHS RoHS Compliant

SPECIFICATIONS

Input Power	Control: 18.0 to 30 VAC at 50/60 HZ AC
Input Current	300 mA @ 24 VAC, gas valve relays energized @ 25°C
Gas Valve	2.0A @ 24 VAC (4.0A Inrush)
Operating Temperature	-40°F to + 176°F (-40°C to +80°C)
Storage Temperature	-40°F to + 185°F (-40°C to +85°C)
Flame Sensitivity	0.7uA minimum
Flame Failure Response Rate	0.8 seconds maximum
Flame Failure Lockout Time	Varies by model, 270 seconds maximum
Gas Types	Natural, LP, or manufactured
Spark Rate	50/60 sparks/sec
Size (LxWxH) Board Only	5.5 x 3.75 x 1.5 inches (13.97 x 9.53 x 3.8 cm)
Size (LxWxH) with Cover	5.7 x 4.0 x 1.6 inches (14.45 x 10.15 x 4.1 cm)
Enclosure / Mounting	Noryl Gray Cover or Integral standoffs
Moisture Resistance	Conformal coated to operate to 95% R.H. (Non-Condensing) Avoid direct exposure to water.
Ingress Protection	Not Rated, Protection provided by appliance in which it is installed.
Tries for Ignition	One or Three
Tries for Ignition Periods	4, 7, 10, or 15 seconds
Pre-purge and Inter-purge Timings	None, 15, or 30 seconds Without pre-purge, there is a 2 second start-up delay.
Alarm modes and Communication	Standard NC, True Alarm, or Fan Control. Optional UART communication

SEQUENCE OF OPERATION / FLAME RECOVERY / SAFETY LOCKOUT

Power Up

During power up the Red LED shall briefly flash ON for around 1 second while the control resets and then turns OFF to indicate normal operation.

Start Up - Heat Mode

When a call for heat is received from the thermostat, 24 VAC to TH, the control begins a pre-purge delay. Following the pre-purge period, the gas valve is energized and sparking commences at both electrodes for the Trial for Ignition (TFI) period.

When both flames are detected during the TFI, the sparking process is terminated and the gas valve remains energized. The thermostat and burner flame are constantly monitored to assure proper system operation. When the thermostat is satisfied and the demand for heat ends, the gas valve is immediately de-energized.

Failure to Light - Lockout

SINGLE TRIAL MODEL

Should either burner fail to light, or a flame is not detected during the TFI period, the gas valve will de-energize and the control will go into lockout.

MULTI TRIAL MODEL

Should either burner fail to light or the flame is not detected during the TFI period, the gas valve will de-energize. The control will then go through an inter-purge delay before an additional ignition attempt. The control attempts two additional ignition trials before de-energizing the gas valve and entering lockout.

Flame Failure - Recycle Mode

If the established flame signal is lost from either burner the gas valve is de-energized and the control proceeds to inter-purge before attempting to relight the flame. Multi-try models permit three tries for ignition including inter-purges. If the burner relights, normal operation resumes. If the burner does not relight, the control will enter lockout.

Flame Failure - Re-Ignition Mode

If the established flame signal is lost while the burner is operating, the control will respond within 0.8 seconds by immediately energizing the H.V. spark for the TFI period in an attempt to relight the flame. If the burner does not light within the TFI, the gas valve will immediately de-energize and single try models will enter lockout. On multi-try models, a new TFI sequence will begin after an inter-purge delay. Multi-try models perform two additional attempts to light the burner. If the burner relights, normal operation resumes. If the burner does not relight, the control will enter lockout after an optional post-purge period.

Lockout Recovery

Recovery from lockout requires either resetting the thermostat, or removing power for a period of 5 seconds. On models with automatic reset, if the thermostat is still calling for heat after one hour, then the control will automatically reset and attempt to ignite the burner.







Fan Control Accessory (FCA) Board - Optional

The FCA wired in conjunction with the 35-62 will provide fan power for the pre-purge and inter-purge times configured in the 35-62. The FCA also supports fan post-purge time after the call for heat is removed.

MOUNTING AND WIRING

The 35-62 is not position sensitive and can be mounted vertically or horizontally. The control may be mounted on any surface and fastened with #6 sheet metal screws. Secure the control in an area that will experience a minimum of vibration and remain below the maximum ambient temperature of 176°F (80°C).

All connections should be made with UL approved, 105°C rated, 18 gauge stranded wire with .054" minimum insulation thickness. Refer to the appropriate wiring diagram when connecting the 35-62 to other components in the system.

 CAUTION	Label all wires prior to disconnection when servicing or replacing controls. Wiring errors can cause improper and dangerous operation. A functional checkout of a replacement control should always be performed.
 CAUTION	The control must be mounted and located in a manner which protects components from exposure to water (dripping, condensate, spraying, rain). Any control that has been exposed to water must be replaced.
 WARNING	All wiring must be done in accordance with both local and national electrical code, and by a trained service technician. Wiring must be at least #18 AWG /AWM rated for 105°C or higher.
 WARNING	The 35-62 uses voltages of shock hazard potential. Wiring and initial operation must be done by qualified service technician.
 WARNING	Operation outside specifications could result in failure of the Fenwal Controls product and other equipment with injury to people and property.
 WARNING	Do not disconnect any electrical loads while the automatic gas ignition control is powered. Disconnect power prior to installation or replacement of the control with the end use appliance.

TERMINAL DESIGNATIONS

Name	Description	Terminal Type
R	Power	1/4" male Q.C.
GND	Ground (Qty 2)	3/16" male Q.C.
V1	Gas Valve	3/16" male Q.C. or .156 pin (2)
V2	Gas Valve GND	3/16" male Q.C. or .156 pin (3)
NC/ ALM	NC Contact, Alarm Out, or FCA	1/4" male Q.C. or .156 pin (4)
TH/W	Thermostat	1/4" male Q.C. or .156 pin (5)
S1	Remote Flame Sense 1	1/4" male Q.C. or .156 pin (1)
S2	Remote Flame Sense 2	1/4" male Q.C. or .156 pin (6)
HV1	H.V. Spark 1	1/4" male Q.C.
HV2	H.V. Spark 2	1/4" male Q.C.
P3	Serial Coms TX, RX, Gnd	0.025 pins 0.1 centers
P2	Remote Diagnostic LED K, A	0.025 pins 0.1 centers

WIRING DIAGRAMS

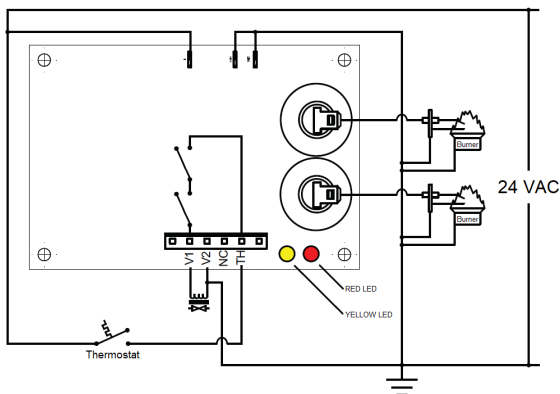

Figure 1. Local Sense

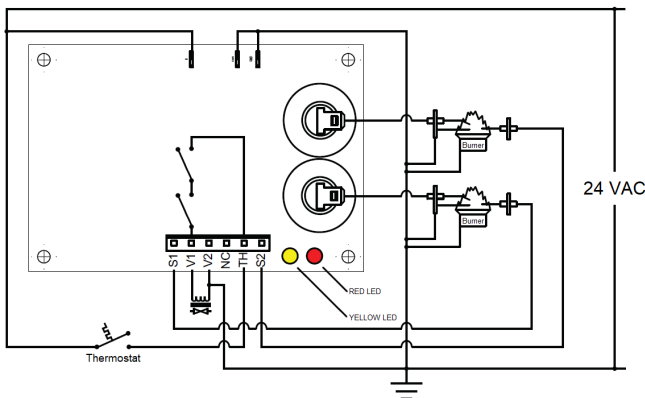

Figure 2. Remote Sense

DIMENSIONS

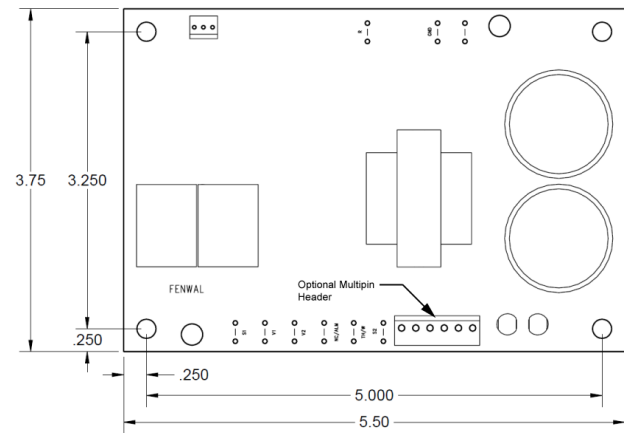

Figure 3. Board Only

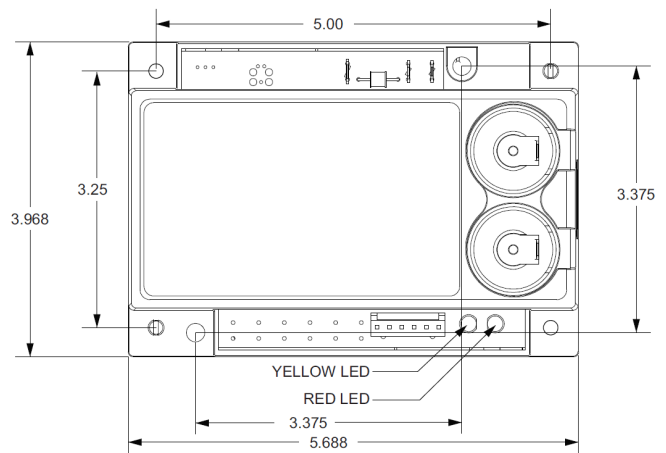

Figure 4. Control with Cover

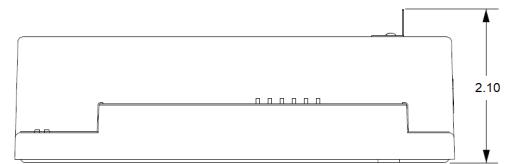

Figure 5. Cover Side View

HIGH VOLTAGE AND REMOTE SENSE CABLE REQUIREMENTS

The HV Ignition Cable should have a voltage rating of 25KV and an insulation rating of 200C. Suppression type UL 3257 or SAE J2031 ratings are recommended. Recommend length of 3ft (.9m) or less. Consult Fenwal Controls for longer lengths.

Remote flame sense cable must meet a voltage rating of 250V and an insulation rating of 200 °C. Recommended length of 10ft (3m) or less. Consult Fenwal Controls for longer lengths.

Refer to Fenwal Controls datasheet F-05-1000 for details.

SPARK ELECTRODES/FLAME SENSORS

Critical for gas-fired appliances, proper design, construction, and application assures reliable ignition and optimal performance. Fenwal Controls recommends glazed Alumina ceramics and certified rod materials suitable up to 2550°F (1400°C). Spark electrodes typically have a 0.125" gap between the high voltage (HV) rod tip and the ground rod or burner. Flame sensors are a single rod used in flame rectification circuit of the ignition control to confirm the presence (or absence) of the flame.

Refer to Fenwal Controls datasheet F-22-100 for details.

Proper Electrode Location

Proper location of electrode assembly is important for optimum system performance. The electrode assembly should be located so that the tips are inside the flame envelope and about 1/2-inch (1.2 cm) above the base of the flame as shown:

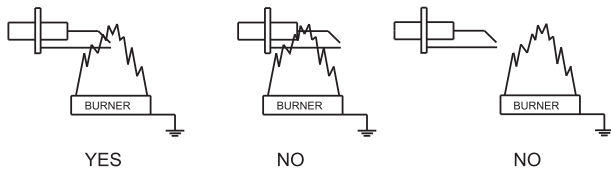

Notes:

- Ceramic insulators must not be in or close to the flame. Electrode assemblies must not be adjusted or disassembled. Electrodes are NOT field adjustable.
- Electrodes should have a gap spacing of 0.125 ± 0.031 in (3.12 ± 0.81 mm), unless otherwise specified by the appliance manufacturer. If spacing is not correct, the assembly must be replaced.
- Exceeding temperature limits can cause nuisance lockouts and premature electrode failure.
- Electrodes must be located where they are not easily accessible during normal operation.

Flame Current Measurement

Flame current is the current which passes through the flame from the sensor to ground to complete the primary safety circuit. The minimum flame current necessary to keep the system from lockout is $0.7 \mu\text{A}$. A good burner ground that matches the control ground is critical for reliable flame sensing.

Flame Current LED

Flame currents of the two channels are simultaneously monitored. The yellow LED provides current status for the lower flame strength out of the two burners.

Flame Conditions – Yellow Flame Sense LED	
LED Indication	Fault Mode
Off	Not in Burn mode
5 flashes	Low flame current (1uA or less)
7 flashes	Nominal flame current (>1uA)

Note: LED will toggle on for 100ms and off for 300ms as needed to indicate a message. The code will repeat every 3.2 seconds.

TROUBLESHOOTING



Risk of Explosion or Fire

The 35-62 cannot be service by the user, this can lead to risk of fire and voids warranty. If controls faults are detected the 35-62 must only be replaced by a qualified service personnel.

Do not use aluminum wire, this can also lead to risk of fire.

Symptom	Recommended Actions
1. Control does not start, Dead	A. Miswired B. Transformer bad/battery fault C. Fuse/circuit breaker fault D. No voltage at PWR E. Faulty control
2. Valve on, no spark	A. Miswired B. Shorted electrode C. Open HV cable D. Faulty control
3. Spark on, no valve	A. Valve coil open B. Open valve wire C. Faulty control (check voltage between V1 and V2)
4. Flame okay during TFI, No flame sense (after TFI)	A. Check electrode position B. Check high voltage wire C. Poor ground at burner D. Poor flame, check flame current

Fault Conditions – Red diagnostic LED	
LED Indication	Fault Mode
Off	Standby & Normal Condition
Steady On	Internal Control Failure
2 flashes	False Flame
3 flashes	Ignition Lockout

Note: During a fault condition, the LED will toggle on for 100ms and off for 300ms as needed to indicate fault code. The code will repeat every 3.2 seconds. Removing power from the control clears the fault code.

Internal Control Failure

If the control detects a software or hardware error, all outputs are turned off. If this condition persists after an attempt to restart, then the control must be replaced.

Communications

A communications option is available. Asynchronous serial with 5v single level swing. Consult factory for details.

Disposal

End of life proper disposal of control required.

STANDARD PART NUMBER CONFIGURATION

35 – 6 2 6 X X X – X X X

Description

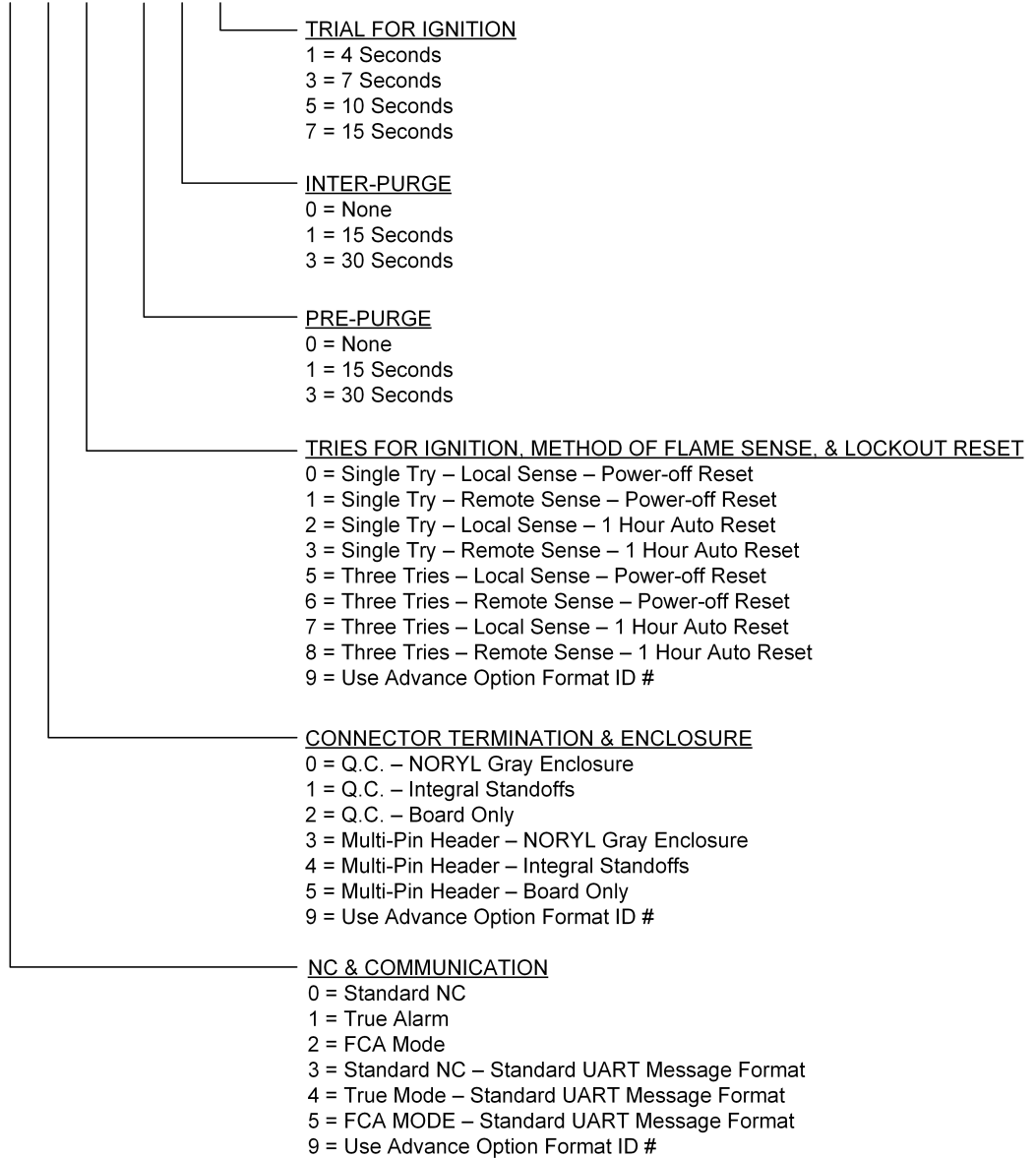

Note: 35-626999-XXX Uses Fenwal Control's advanced Option ID # for additional options.
 The XXX becomes the product's unique identifier.

EXPORT INFORMATION (USA)

Jurisdiction: EAR
 Classification: EAR99

All trademarks are property of their respective owners.

This document contains technical data subject to the EAR.



Fenwal Controls, Kidde-Fenwal Inc.
 400 Main Street
 Ashland, MA 01721
 Tel: 800-FENWAL-1
 Fax: 508-881-7619
fenwalcontrols.com

This literature is provided for informational purposes only. KIDDE-FENWAL, INC. assumes no responsibility for the product's suitability for a particular application. The product must be properly applied to work correctly. If you need more information on this product, or if you have a particular problem or question, contact KIDDE-FENWAL, INC., Ashland, MA 01721.